

GENERAL

- | | | | |
|---|--|--|---|
| <input checked="" type="checkbox"/> TOP LATCH | <input checked="" type="checkbox"/> INTERNAL DRIVE | <input type="checkbox"/> LIGHTNING ARRESTOR | <input checked="" type="checkbox"/> ONE CIRCUIT |
| <input type="checkbox"/> BOTTOM LATCH | | <input type="checkbox"/> AIR TERMINAL | <input type="checkbox"/> TWO CIRCUIT |
| <input type="checkbox"/> EXTERNAL DRIVE | | <input type="checkbox"/> FAA OBSTRUCTION LIGHT | <input type="checkbox"/> THREE CIRCUIT |

04 HEAD FRAME

- | | | | |
|---|--|--|---|
| WELDMENT: | <input checked="" type="checkbox"/> GALVANIZED (STD) | <input type="checkbox"/> STAINLESS STEEL | <input type="checkbox"/> PAINTED |
| MOUNT: | <input type="checkbox"/> TOP PLATE | <input type="checkbox"/> SLIP FITTER | |
| HOIST SHEAVES: | <input checked="" type="checkbox"/> ALUMINUM (STD) | <input type="checkbox"/> STAINLESS STEEL | <input type="checkbox"/> CAD PLATED STEEL |
| CORD SHEAVE: | <input checked="" type="checkbox"/> PLASTIC (STD.) | <input type="checkbox"/> ALUMINUM | <input type="checkbox"/> STAINLESS STEEL |
| FASTENERS: | <input checked="" type="checkbox"/> STAINLESS STEEL | | |
| S.S. CABLE: | <input checked="" type="checkbox"/> 3/16" | <input type="checkbox"/> 1/4" | <input type="checkbox"/> 5/16" <input type="checkbox"/> OTHER |
| <input checked="" type="checkbox"/> TOP LATCH | | | |
| LATCH CAM: | <input checked="" type="checkbox"/> STAINLESS STEEL | <input type="checkbox"/> ALUMINUM | |
| <input type="checkbox"/> BOTTOM LATCH | | | |
| GUIDE BLOCK: | <input type="checkbox"/> STAINLESS STEEL | <input type="checkbox"/> ALUMINUM | |

ISSUED FOR APPROVAL

APPROVED: _____

REVISE: _____

SIGNED COPY REQUIRED PRIOR TO MANUFACTURE

05 LUMINAIRE RING

- | | | | |
|---|---|--|--|
| WELDMENT: | <input checked="" type="checkbox"/> GALVANIZED (STD) | <input type="checkbox"/> STAINLESS STEEL | <input type="checkbox"/> PAINTED |
| ROLLERS: | <input checked="" type="checkbox"/> SPRING ARM | <input type="checkbox"/> FIXED | <input type="checkbox"/> BUMPER |
| <input checked="" type="checkbox"/> TOP LATCH | | <input type="checkbox"/> BOTTOM LATCH | |
| LATCH SHAFT: | <input checked="" type="checkbox"/> STAINLESS STEEL | GUIDE SHAFT: | <input type="checkbox"/> STAINLESS STEEL |
| JUNCTION BOX: | <input checked="" type="checkbox"/> STD. (NEMA 3R ALUMINUM) | | <input type="checkbox"/> STAINLESS STEEL <input type="checkbox"/> OTHER |
| SUSPENSION SPRING: | <input checked="" type="checkbox"/> STD. | <input type="checkbox"/> STAINLESS STEEL | |
| PLUNGER: | <input checked="" type="checkbox"/> STD. | <input type="checkbox"/> STAINLESS STEEL | |
| THRUST WASHER: | <input checked="" type="checkbox"/> STD. | <input type="checkbox"/> STAINLESS STEEL | |
| STRAND VICE: | <input checked="" type="checkbox"/> STD. | <input type="checkbox"/> STAINLESS STEEL | <input checked="" type="checkbox"/> 3/16" <input type="checkbox"/> 1/4" <input type="checkbox"/> 5/16" |

COMMENTS: _____

08 ELECTRICAL

- 120V 1 PHASE-3 WIRE 60Hz
- 120/240 3 PHASE-5 WIRE 60Hz
- 208 1 PHASE-3 WIRE 60Hz
- 208 3 PHASE-4 WIRE 60Hz
- 240 1 PHASE-3 WIRE 60Hz
- 120/240 1 PHASE-4 WIRE 60Hz
- 240/480 1 PHASE-4 WIRE 60Hz
- 277 1 PHASE-3 WIRE 60Hz
- 277/480 3 PHASE-5 WIRE 60Hz
- 480 1 PHASE-3 WIRE 60Hz
- 480 3 PHASE-4 WIRE 60Hz
- 220 1 PHASE-3 WIRE 60Hz
- 347 1 PHASE-3 WIRE 60Hz
- 347/600 3 PHASE-5 WIRE 60Hz
- 220 1 PHASE-3 WIRE 50Hz
- 240 1 PHASE-3 WIRE 50Hz
- 240/415 3 PHASE-5 WIRE 50Hz
- 220/380 3 PHASE-5 WIRE 50Hz
- OTHER

06 TRANSITION ASSEMBLY

- STANDARD OTHER

COMMENTS:

07 WINCH PLATE

- | | | | |
|----------------|--|--|---|
| DRIVE: | <input checked="" type="checkbox"/> INTERNAL | <input type="checkbox"/> EXTERNAL | |
| | <input checked="" type="checkbox"/> 1.5 HP (STD) | <input type="checkbox"/> 2.0 HP (HD) | <input type="checkbox"/> PORTABLE DRIVE UNIT |
| | | | <input type="checkbox"/> TRANSFORMER |
| | | | <input type="checkbox"/> MOBILE DRIVE CART |
| TORQUE TENDER: | <input checked="" type="checkbox"/> TT3 (STD) | <input type="checkbox"/> TT3X | <input type="checkbox"/> TT4 <input type="checkbox"/> OTHER |
| WINCH: | <input checked="" type="checkbox"/> PG-3 | <input type="checkbox"/> PG-7 | |
| S.S. CABLE: | <input checked="" type="checkbox"/> 1/4" | <input type="checkbox"/> 5/16" <input type="checkbox"/> 3/8" | <input type="checkbox"/> OTHER |

COMMENTS: _____

SHEET
01

PROVISIONS SHEET

DWG. NO.	428-2-01
DATE:	09/26/05
REV. DATE	



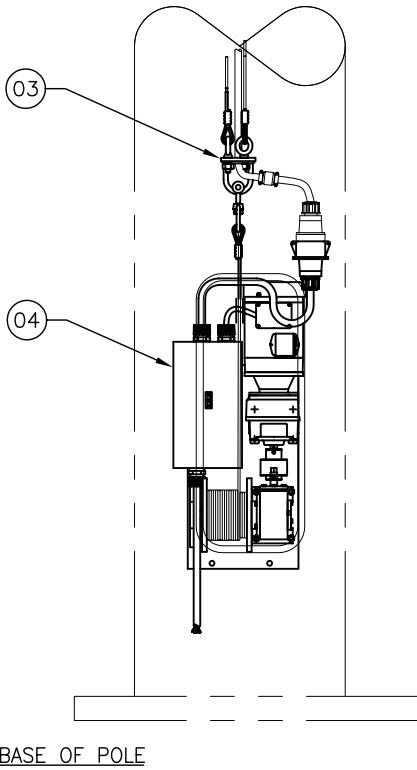
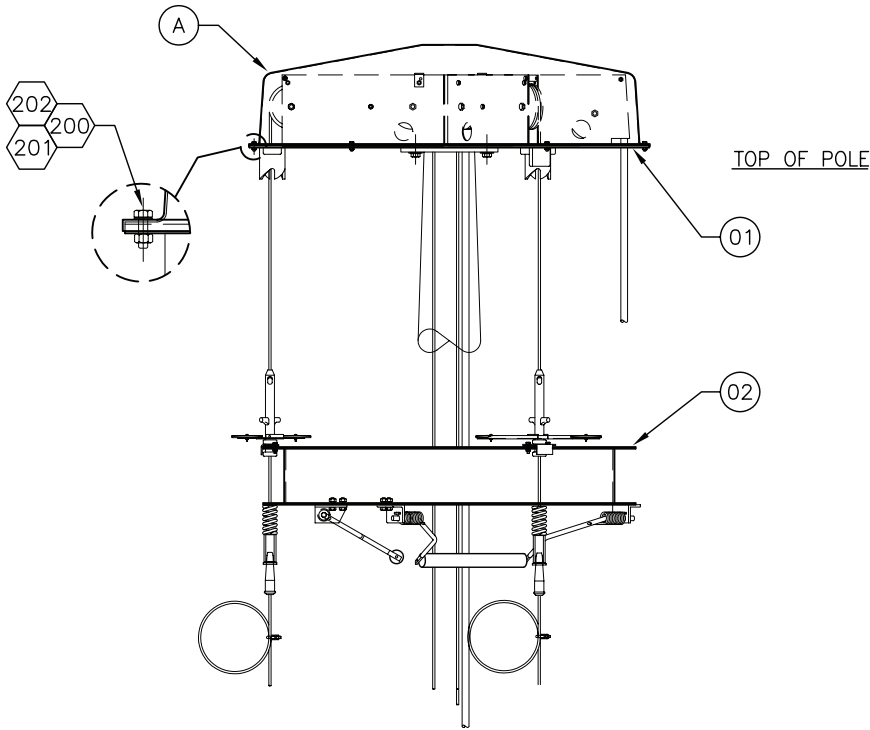

ISSUED FOR APPROVAL

APPROVED: _____

REVISE: _____

SIGNED COPY REQUIRED PRIOR TO MANUFACTURE

202	6	S.S. FLAT WASHER
201	6	1/4-20 S.S. NYLOCK NUT
200	6	1/4-20 X 1" S.S. BOLT
05	1	ALUMINUM DOME
04	1	WINCH PLATE ASSEMBLY
03	1	TRANSITION ASSEMBLY
02	1	RING ASSEMBLY
01	1	HEAD FRAME ASSEMBLY
ITM	QTY	DESCRIPTION

SHEET
02

GENERAL ASSEMBLY

DWG. NO.

428-2-02

DATE:

09/26/05

REV. DATE



A Division of CHM Industries
682-286-0046

ISSUED FOR APPROVAL

APPROVED: _____

REVISE: _____

SIGNED COPY REQUIRED PRIOR TO MANUFACTURE

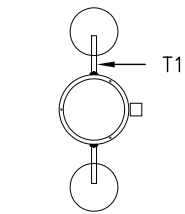

2-FIXTURE

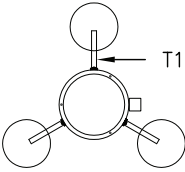

3-FIXTURE

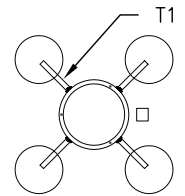

4-FIXTURE

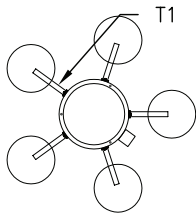

5-FIXTURE

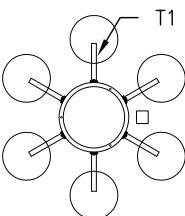

6-FIXTURE

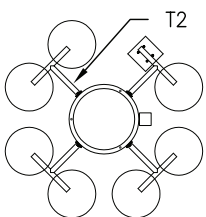

7-FIXTURE

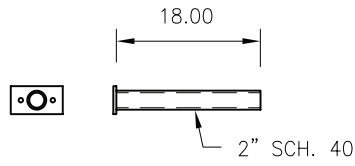

TENON T-1

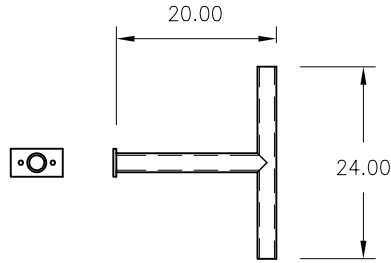

TENON T-2

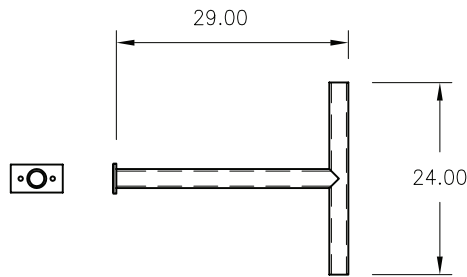

TENON T-3

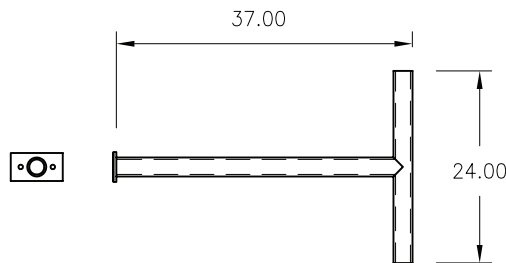

TENON T-4

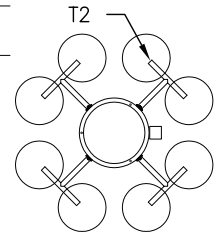

8-FIXTURE

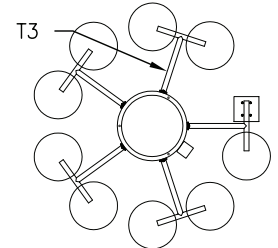

9-FIXTURE

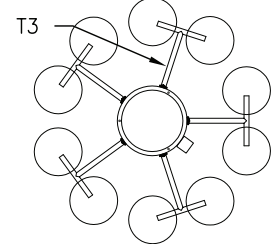

10-FIXTURE

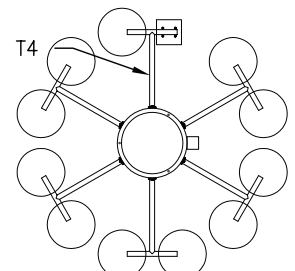

11-FIXTURE

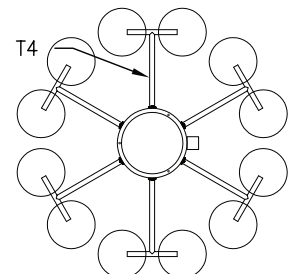

12-FIXTURE

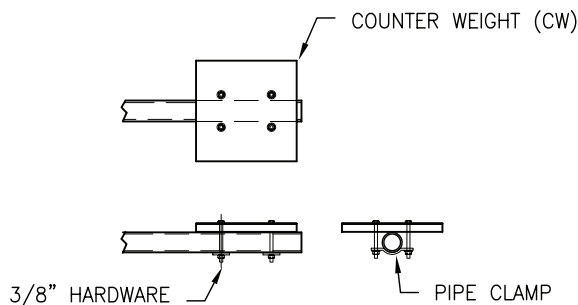

COUNTER WEIGHT DETAIL

SHEET
03

FIXTURE ARRAY DRAWING

DWG. NO.	428-2-03
DATE:	09/26/05
REV.	

CHM
LIGHTING
A Division of CHM Industries
682-286-0046

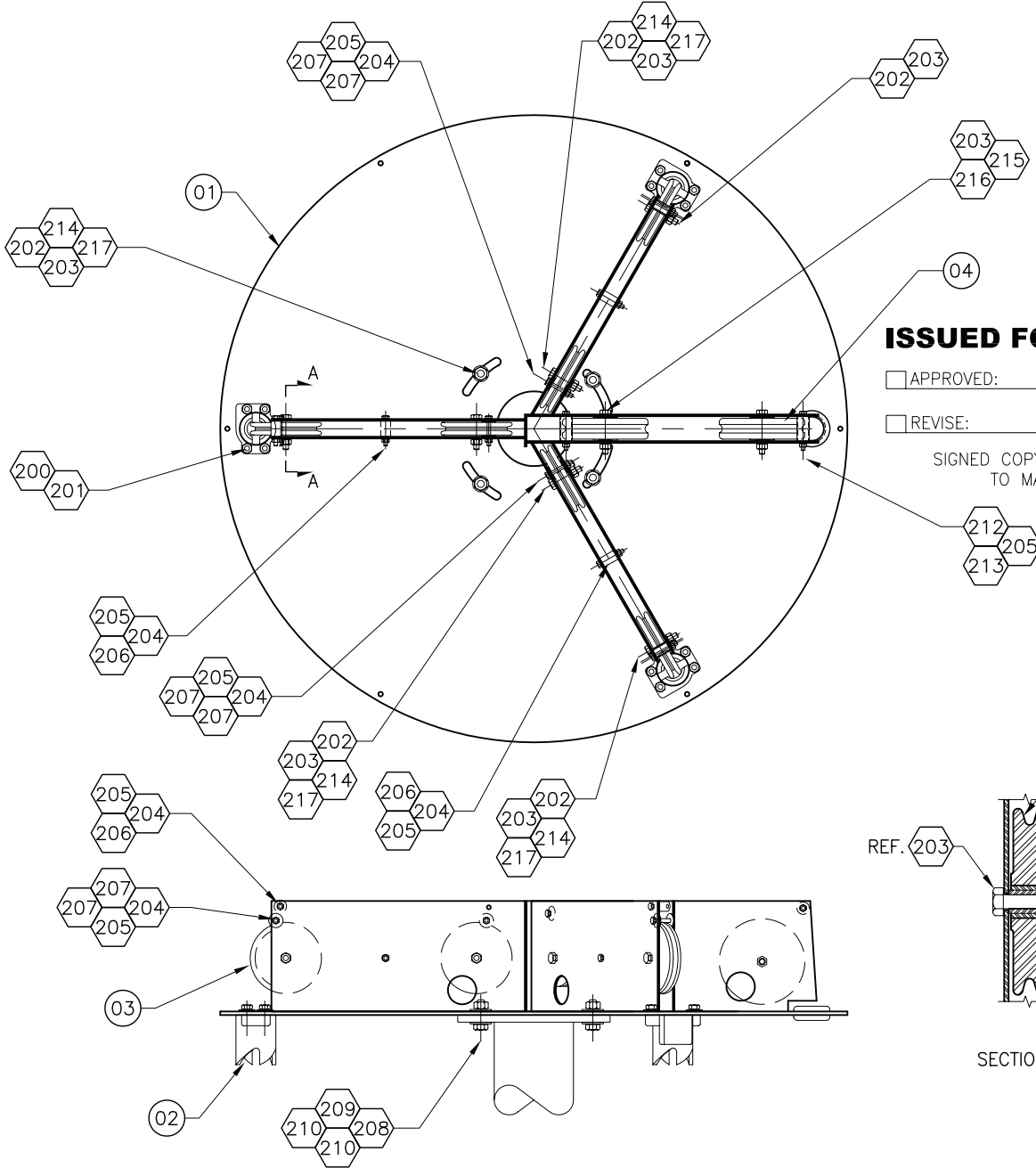

ISSUED FOR APPROVAL

APPROVED: _____

REVISE: _____

SIGNED COPY REQUIRED PRIOR TO MANUFACTURE

210	8	1/2" S.S. FLAT WASHER		
209	4	1/2-16 S.S. LOCK NUT		
208	10	1/2" S.S. FLAT WASHER		
207	12	1/4" X 1 1/4" FLAT FENDER WASHER		
206	6	1/2" SCH. 40 X 1 1/8" LONG TUBE SPACER		
205	13	1/4-20 S.S. LOCK NUT		
204	13	1/4-20 X 1 3/4 S.S. HH SHOULDER BOLT		
203	8	3/8-16 S.S. LOCK NUT		
202	8	3/8-16 X 2" S.S. HH SHOULDER BOLT		
201	12	3/8" S.S. LOCK NUT	217	6
200	12	3/8-16 X 1" S.S. HH BOLT	216	2
100	1	PLASTIC BUSHING	215	2
04	2	CORD SHEAVE	214	6
03	6	WIRE ROPE SHEAVE	213	2
02	3	LATCH CAM	212	2
01	1	HEADFRAME WELDMENT ASSEMBLY	211	
ITM	QTY	DISCRIPTION		NOT USED

SHEET

04

HEAD FRAME ASSEMBLY

DWG. NO.

428-2-04

DATE:

09/26/05

REV. DATE



A Division of CHM Industries
682-286-0046

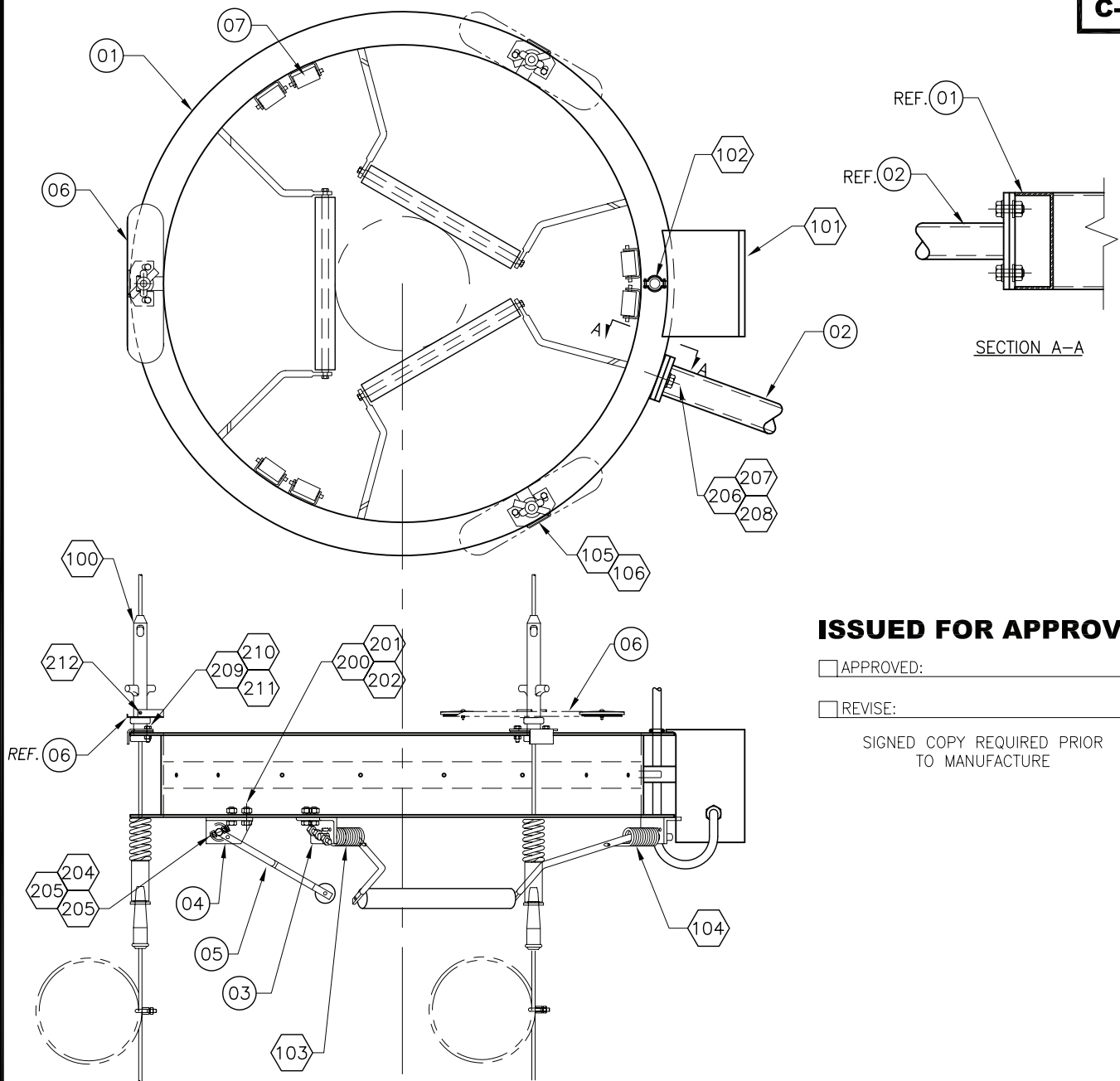

ISSUED FOR APPROVAL

APPROVED: _____

REVISE: _____

SIGNED COPY REQUIRED PRIOR TO MANUFACTURE

ITEM	QTY	DESCRIPTION
106	3	RUBBER GASKET
105	3	SHAFT RETAINING BRACKET
104	3	RH TORSION SPRING
103	3	LH TORSION SPRING
102	1	CORD CLAMP
101	1	JUNCTION BOX
100	3	LATCH SHAFT
07	6	FIXED ROLLER ASSEMBLY
06	3	LATCH INDICATOR FLAG
05	3	CENTERING ARM ASSEMBLY - S.S./PVC
04	3	RH CENTERING ARM HINGE BRACKET
03	3	LH CENTERING ARM HINGE BRACKET
02	VAR	TENON WELDMENT
01	1	RING WELDMENT

212	3	#10-24 X 1/2" S.S. SCREW
211	6	5/16 S.S. FLAT WASHER
210	6	5/16-18 S.S. LOCK NUT
209	6	5/16-18 X 1" S.S. HH BOLT
208	VAR	1/2-13 S.S. FLAT WASHER
207	VAR	1/2-13 S.S. LOCK NUT
206	VAR	1/2-13 X 1 1/2 S.S. HH BOLT
205	12	1/4-20 S.S. LOCK NUT
204	6	1/4-20 X 1 1/2 S.S. HH BOLT
203	3	S.S. "E" RETAINING RING
202	12	3/8" S.S. FLAT WASHER
201	14	3/8-16 S.S. LOCK NUT
200	14	3/8-16 X 1" S.S. HH BOLT

SHEET		DWG. NO.	428-2-05
05	RING ASSEMBLY	DATE:	09/26/05
		REV. DATE	

 A Division of CHM Industries 682-286-0046		

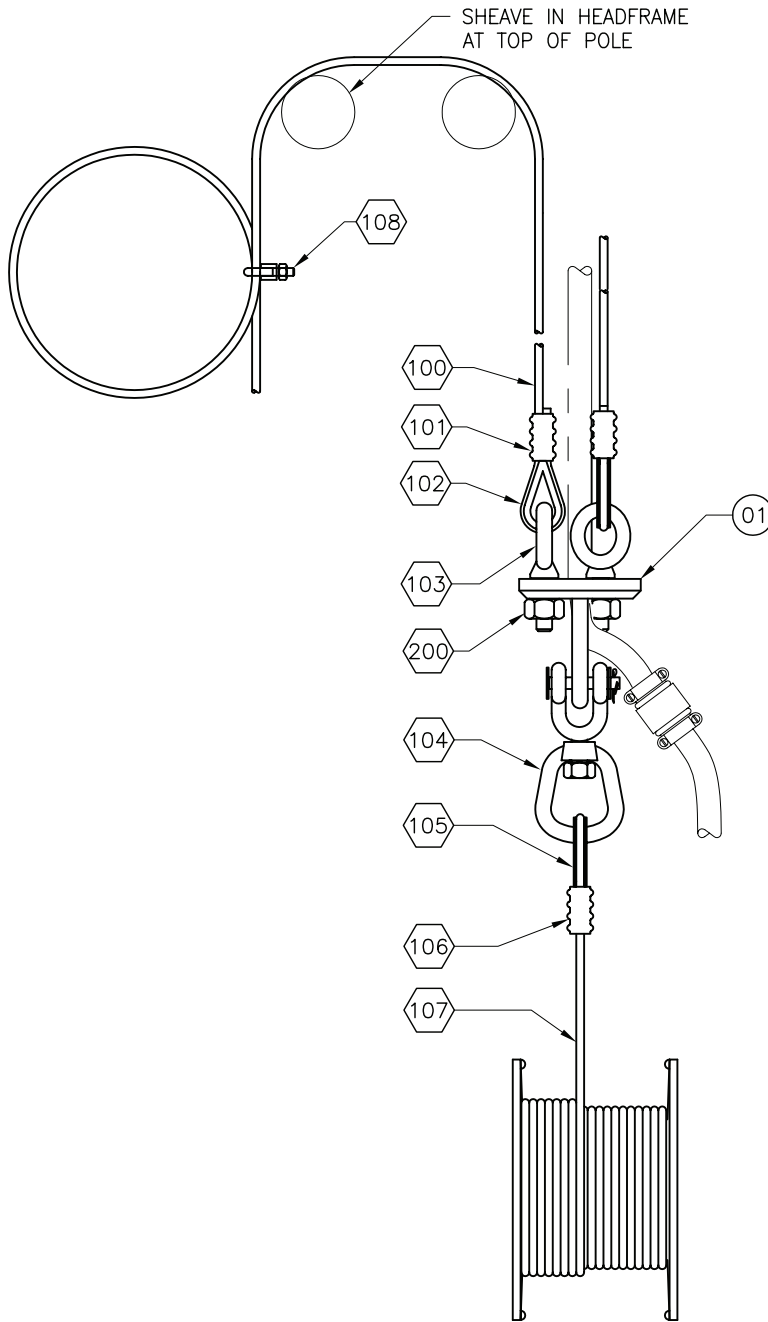

ISSUED FOR APPROVAL

APPROVED: _____

REVISE: _____

SIGNED COPY REQUIRED PRIOR
TO MANUFACTURE

ITEM	QTY	DESCRIPTION
200	3	1/2-13 S.S. LOCK NUT
108	3	CABLE CLAMP ASSEMBLY
107	1	7-19 302/304 WIRE ROPE
106	1	ZINC PLATED COPPER COMPRESSION SLEEVE
105	1	WIRE ROPE THIMBLE
104	1	1/2" JAW AND EYE ASSEMBLY
103	3	1/2" EYE BOLT, ZINC PLATED
102	3	WIRE ROPE THIMBLE
101	3	ZINC PLATED COPPER SLEEVE
100	3	7-19 302/304 S.S. WIRE ROPE
01	1	TRANSITION PLATE WELDMENT ASSEMBLY
ITM	QTY	DESCRIPTION

SHEET 06	TRANSITION ASSEMBLY	DWG. NO.	428-2-06	 A Division of CHM Industries <small>682-286-0046</small>
		DATE:	09/26/05	
		REV. DATE		

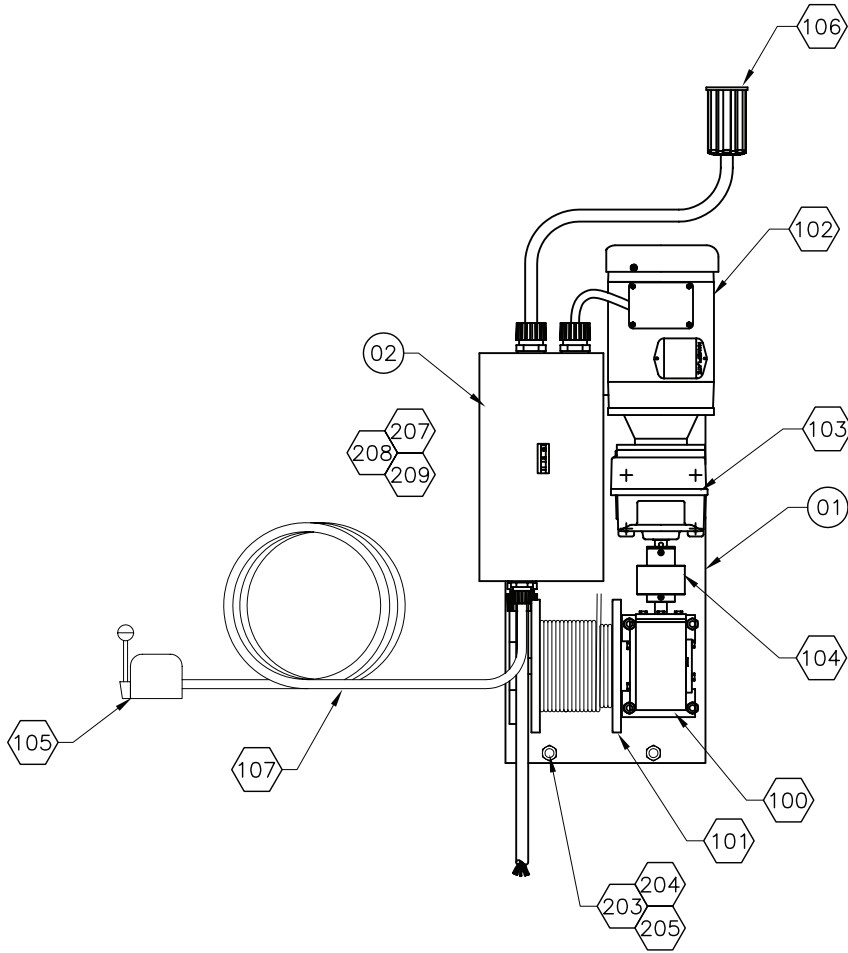

ISSUED FOR APPROVAL

APPROVED: _____

REVISE: _____

SIGNED COPY REQUIRED PRIOR
TO MANUFACTURE

206	4	1/4" S.S. FLAT WASHER
205	4	1/4-20 S.S. LOCK NUT
204	4	1/4-20 X 1" S.S. HH BOLT
203	6	1/2-13 X 2" S.S. HH BOLT
202	9	1/2" S.S. FLAT WASHER
201	9	1/2-13 S.S. LOCK NUT
200	3	1/2-13 X 4" S.S. STUD
107	1	25 FT CORD
106	1	MALE CONNECTOR
105	1	DRUM SWITCH
104	1	TORQUE TENDER
103	1	REDUCER
102	1	DRIVE MOTOR
101	1	ROPE SPOOL
100	1	WINCH
02	1	BREAKER BOX ASSEMBLY
01	1	WINCH PLATE
ITM	QTY	DESCRIPTION

SHEET

07

WINCH PLATE ASSEMBLY

DWG. NO.

428-2-07

DATE:

09/26/05

REV. DATE



A Division of CHM Industries
682-286-0046